

# Iron Check Valves

## PN16/235PSI/Class125

Horizontal Swing, Bronze Seat

Design to BS5153 and MSS SP-71

Flange Dimension to EN1092-2, ANSI B16.1 Class 125



**CF670-Y**

2" - 24"

Hydraulic Pressure Test	
Body	2.4Mpa/24Bar
Seat	1.76Mpa/17.6Bar

Pressure Ratings	
	1.0 Mpa at 180°C
	1.6 Mpa at -10°C-120°C

### Materials List

No	Part	Specification	BS EN	ASTM
1	Body	Cast Iron	BSEN 1561	A126 Class B
2	Seat Sealing Ring	Cast Bronze	1982 CC491K	B62
3	Disc Sealing Ring	Cast Bronze	1982 CC491K	B62
4	Disc	Cast Iron	BSEN 1561	A126 Class B
5	Support	Ductile Iron	BSEN 1563	A536 65-45-12
6	Gasket	Steel	BSEN 10087	Steel A307
7	Nut	Steel	BSEN 10087	Steel A307
8	Safety Pin	Stainless Steel	BSEN 10088-1	AISI 304
9	Screw	Steel	BSEN 10087	Steel A307
10	Support Pin	Brass	12164 CW603N	B16
11	Gasket	Steel	BSEN 10087	Steel A307
12	Safety Pin	Stainless Steel	BSEN 10088-1	AISI 304
13	Bonnet	Cast iron	BSEN 1561	A126 Class B
14	Bonnet Gasket	Graphite	---	--
15	Bolt	Steel	BSEN 10087	Steel A307
16	Nut	Steel	BSEN 10087	Steel A307

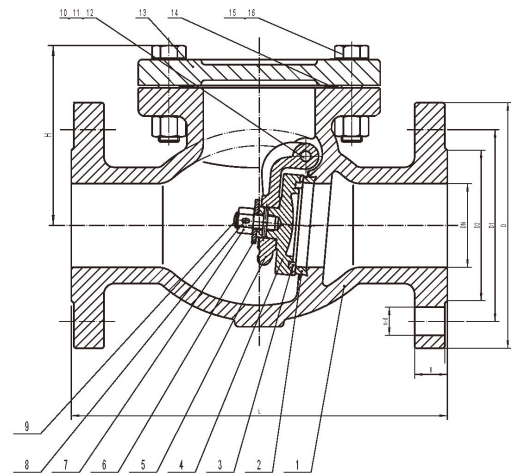

### Dimensions-Weights

mm	50	65	80	100	125	150	200	250	300	350	400	450	500	600
In	2	2½	3	4	5	6	8	10	12	14	16	18	20	24
L	203	216	241	292	330	356	495	622	699	787	914	914	1016	1219
H	112	132	141	162	192	211	270	316	357	560	589	645	702	812
D	165	185	200	220	250	285	340	405	460	520	580	640	715	840
D1	125	145	160	180	210	240	295	355	410	470	525	585	650	770
D2	99	118	132	156	184	211	266	319	370	429	480	548	609	720
B	20	20	22	24	26	26	30	32	32	36	38	40	42	48
n-d	4-19	4-19	8-19	8-19	8-19	8-23	12-23	12-28	12-28	16-28	16-31	20-31	20-34	20-37
Weight	Lbs	26	39	47	82	160	271	443	642	935	1195	1446	1835	2778
	Kg	12	18	21	37	56	72	123	291	424	542	656	832	1260